



Series  
TCX

SIZE 8 CONCENTRIC TWINAX SOCKET CONTACT REAR RELEASE REAR REMOVABLE  
CABLE P/N:MiL-C-17/176 00002

Issue:  
16 JULY 99

Page  
1 / 1

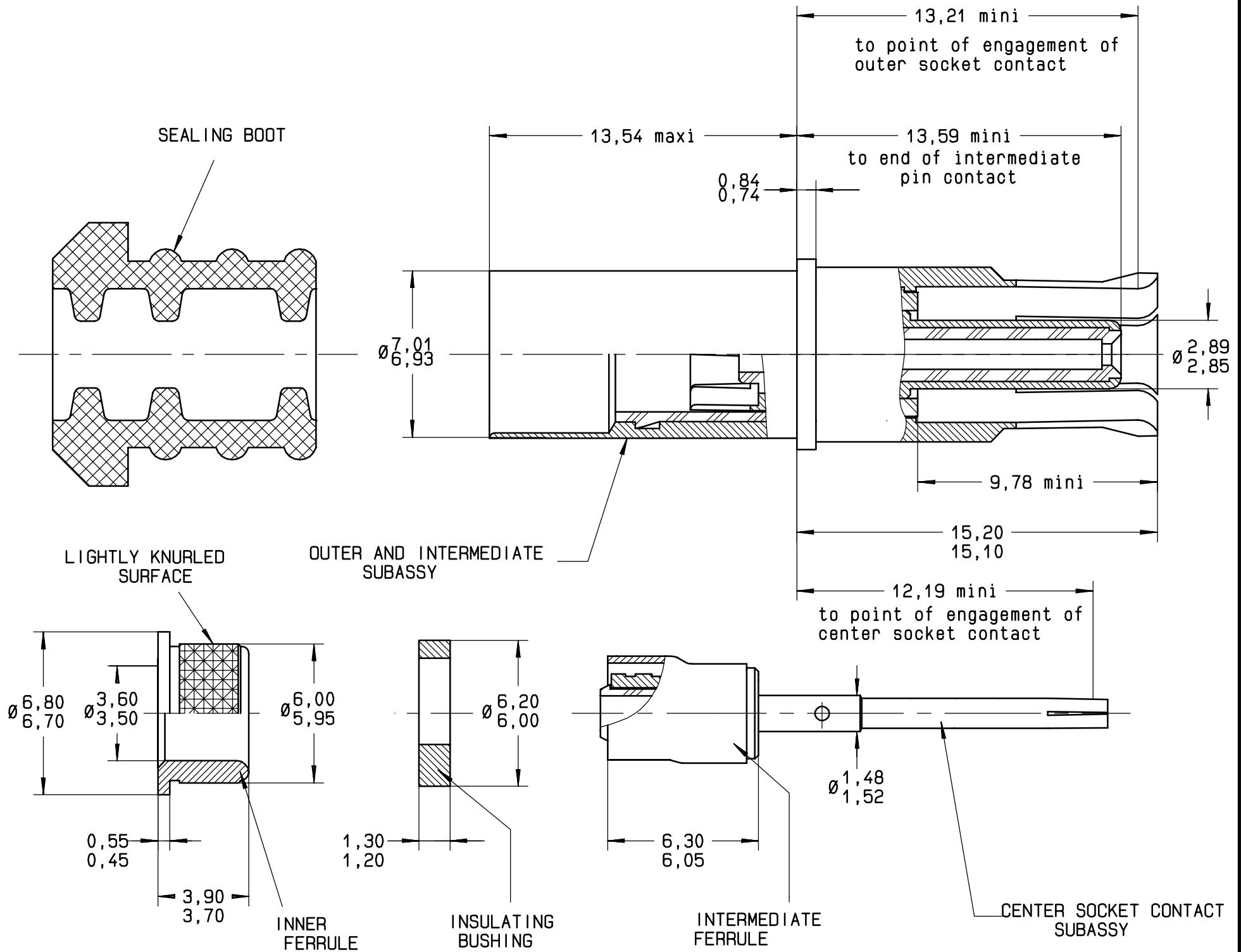

**MATERIALS:**

OUTER AND CENTER CONTACT: BERYLLIUM COPPER ALLOY PER QQ-C-530 HEAT TREATED FOR SPRING TINES, ANNEALED ON CRIMP BARREL  
 INTERMEDIATE CONTACT: BERYLLIUM COPPER ALLOY PER QQ-C-530 HEAT TREATED  
 INTERMEDIATE AND INNER FERRULE: BRASS PER QQ-B-626  
 OUTER, CENTER DIELECTRIC AND INSULATING BUSHING: PTFE  
 SEALING BOOT: FLUOROSILICONE

**FINISHES: (ALL METAL PARTS)**

GOLD PLATE PER MIL-G-45204, TYPE II, GRADE C, CLASS 1 : 50 MICROINCHES OVER NICKEL PLATE PER QQ-N-290, CLASS 2

WIRING INSTRUCTIONS: SEE RP 54431

This information is given as an indication. In the continual goal to improve our products, we reserve the right to make any modifications judged necessary.

4112-9610

CREATION				
PEN: M970106323A				
NOM: B.VAN DEN				
DATE: 21-6-99				
APPR.: BALDYROU	16/07/99	WIRING INST. RP 54431 WAS RP 08820	BALDYROU	
	Issue	Revisions	Name	Approved